

Handwheels with retractable handle

Aluminium, Handle locked

SPECIFICATION

Type

- Type **R**: with retractable handle

Bore codes

- Version **B**: without keyway
- Version **K**: with keyway

Aluminium pressure die casting

- Hub machined
- Rim turned
- plastic coated

black, RAL 9005, textured finish **SW**

silver, RAL 9006, textured finish **SR**

Rim concentric and square to bore < 0.4

Retractable handles GN 798.3 (see page 586)

Plastic, Technopolymer
black, matt

Retracting mechanism
Steel, blackened



reddot design award

INFORMATION

The handle in these handwheels is locked in a conical bore in the operating position.

For reversal, it must first be pulled from the cone in axial direction.

A pressure spring holds the handle in both positions. When swung out, it automatically engages again.

TECHNICAL INFORMATION

- Keyway DIN 6885 (see page A16)
- Cross holes GN 110 (see page A17)
- ISO-Fundamental Tolerances (see page A21)

* Complete with colour index of the Handwheels (SW or SR)

SW **SR**
RAL9005 RAL9006

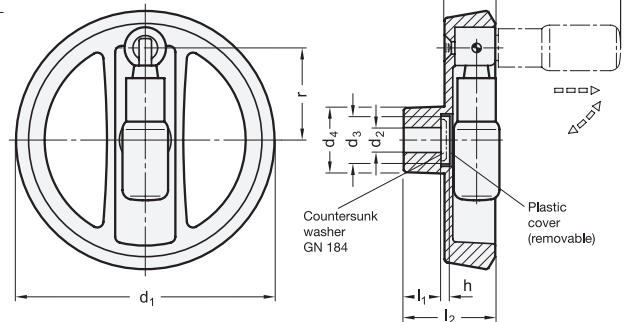

GN 924.3

Description	d1	d2 H7	d3	d4	b	h	l1	l2 ≈	l3 ≈	r ≈	Ø Handle	Recommended countersunk washer	⚖
GN 924.3-125-B12-R-*	125	12	23	31	24.5	4	18	45	60.5	45.5	22	GN 184-22	465
GN 924.3-125-K12-R-*	125	12	23	31	24.5	4	18	45	60.5	45.5	22	GN 184-22	465
GN 924.3-125-B14-R-*	125	14	23	31	24.5	4	18	45	60.5	45.5	22	GN 184-22	450
GN 924.3-125-K14-R-*	125	14	23	31	24.5	4	18	45	60.5	45.5	22	GN 184-22	450
GN 924.3-140-B14-R-*	140	14	23	36	26	4	19	47	75.5	52	24	GN 184-22	600
GN 924.3-140-K14-R-*	140	14	23	36	26	4	19	47	75.5	52	24	GN 184-22	590
GN 924.3-160-B14-R-*	160	14	23	36	26	4	20	48	75.5	61	24	GN 184-22	700
GN 924.3-160-K14-R-*	160	14	23	36	26	4	20	48	75.5	61	24	GN 184-22	690
GN 924.3-140-B16-R-*	140	16	23	36	26	4	19	47	75.5	52	24	GN 184-22	600
GN 924.3-140-K16-R-*	140	16	23	36	26	4	19	47	75.5	52	24	GN 184-22	590
GN 924.3-160-B16-R-*	160	16	23	36	26	4	20	48	75.5	61	24	GN 184-22	700
GN 924.3-160-K16-R-*	160	16	23	36	26	4	20	48	75.5	61	24	GN 184-22	690
GN 924.3-200-B18-R-*	200	18	23	42	27	4	24	53	85.5	80.5	25	GN 184-22	900
GN 924.3-200-K18-R-*	200	18	23	42	27	4	24	53	85.5	80.5	25	GN 184-22	890
GN 924.3-200-B20-R-*	200	20	23	42	27	4	24	53	85.5	80.5	25	GN 184-22	1060
GN 924.3-200-K20-R-*	200	20	23	42	27	4	24	53	85.5	80.5	25	GN 184-22	1000